

# SOUTH POINTE



@

Fort Saskatchewan

Architectural

&

Design Guidelines

Stage 6A RS-4

MLC Group Inc.

July 2011

## CONTENTS:

<u>Section</u>	<u>Description</u>
1.0	OBJECTIVE
2.0	STREETSCAPE
3.0	HOUSE SIZE
4.0	SITE PLANNING AND GRADING
5.0	GARAGE/DRIVEWAY
6.0	IDENTICAL ELEVATION
7.0	EXTERIOR COLORS
8.0	CORNER LOTS
9.0	ROOFING
10.0	EXTERIOR FINISHES
11.0	FENCING
11.1	Landscaping
12.0	ANCILLARY BUILDINGS / GARDEN SHEDS
13.0	INTERPRETATIONS
14.0	SITING
14.1	Consultant
14.2	City Regulations
14.3	Grading
14.4	Plot Plans
15.0	SUBDIVISION APPEARANCE
15.1	Signage
15.2	Excavation Material
15.3	Clean up
15.4	Construction Activity
16.0	APPROVAL PROCESS
17.0	DAMAGE DEPOSITS
17.1	Deposit Return Procedure

## DIRECTORY:

Manager	MLC Group	420-0044 (Fax 423-0044)	Chris Nicholas Shawna Devlin	#1000, 10104 - 103 Avenue Edmonton, AB. T5J 0H8
Engineers	Stantec	917-7000 (Fax 917-7289)	Tariq Mahood	#700, 10160 - 112 Street Edmonton, AB. T5K 2L6
Architectural Applications	Windward Landtec	454-6799 (Fax 454-6896)	Ray Jacobson	12128 - 121 A Street Edmonton, AB. T5L 0A4
Surveyor	Stantec Geomatics	917-7000 (Fax 917-7289)	Brent Rudko	700, 10160 - 112 Street Edmonton, AB. T5K 2L6
Solicitor	Oshry & Company	428-1731 (Fax 420-6290)	Karen Oshry	#1004, 10104 - 103 Avenue Edmonton, AB. T5J 0H8
Geotechnical Consultants	J.R. Paine & Assoc.	489-0700 (Fax 489-0800)	Rick Evans	3051 Parsons Road Edmonton, AB. T6N 1C8

## 1.0 OBJECTIVE

The objective of these architectural guidelines is to ensure the very highest standard of visual appeal and image; ensuring compatibility among homes and integration of the community into the natural landscape. Outlining the opportunities and constraints of building, these guidelines will assist builders, designers and home buyers in achieving problem free construction.

## 2.0 STREETSCAPE

Care must be taken to integrate the unique values of each home with special attention to the relationship with neighboring properties. Relative massing, siting and style will be of utmost importance in assuring each home compliments it's' neighbor and the subdivision. Building massing, siting and style may be adjusted and/or alternate treatments requested to reinforce the streetscape. Entranceways will be covered at a level that encloses and protects the space. The style, width, height and detailing of entranceways will together create a sense of arrival.

## 3.0 HOUSE SIZE

Houses are to have a consistency of mass and volume within the streetscape. As such, house widths and sizes must relate proportionately and logically to the lot width and neighboring houses.

Homes will be reviewed on their individual merits of design, massing, proportion, and compatibility.

## 4.0 SITE PLANNING AND GRADING

Site planning and grading must accommodate the natural slope of the land with variations in grade absorbed within the building mass as much as possible. Lot grading must be in strict conformance with the approved grading plan for the subdivision.

Special attention is to be given the treatment of exposed concrete foundation walls. A maximum of 2'0" of parged concrete will be permitted on the front and corner elevations. Variation in grade and basement design may require cladding material be lowered or extended to within 2'0" of ground level accordingly.

Front entry steps are to be a maximum of three risers per set. Where the grade calls for more than three risers, the run must be split. Exceptions to this requirement may be granted in consideration of unique design, topography and lateral bracing concerns. If there are more than three risers per set, the step will be a minimum of 4' wide with appropriate railing style.

Additional setbacks may be required to articulate and provide streetscape differentiation to all proposed homes. Homes will be reviewed on their individual merits of design, massing, proportion and compatibility and, where the Architectural Consultant considers the plan to be exceptional, and, provided that the house conforms to the general trend of the neighborhood, exceptions may be considered.

## 5.0 GARAGE/DRIVEWAY/WALKWAY

The front walkway must be a minimum of poured concrete in broom finish, 30" wide. Individual patio blocks will not be permitted.

A 20' x 20' poured concrete parking pad must be provided concurrent with house construction. The approach

to the lane may be paved with asphalt or concrete.

Detached garages should be consistent in style, finish, and color with the design of the house.

#### **6.0 IDENTICAL ELEVATIONS**

Similar or approximately identical elevations must not be repeated on adjacent lots or directly across the street (XOAX). To be considered different, an alternate elevation must reflect substantial modifications. Repetitive use of elevations, this includes front elevations as well as high visibility rear elevations will be monitored to ensure interesting streetscapes.

#### **7.0 EXTERIOR COLORS**

Colors will be approved on a lot by lot basis without repetition on adjacent lots. The use of a third accent color is required.

The overhead garage door must be painted to match the wall cladding.

#### **8.0 CORNER LOTS**

Houses on the corner lots require special design consideration. Flanking side elevations should have suitable front elevation treatments with principal roof planes sloping towards view. All models will be considered for corner lots based on their unique suitability to these locations. Two story models this may include variation in wall planes, roof at second floor set back of main floor to provide substantial roof mass between floors, appropriate wall heights, window placement and use of detailing.

#### **9.0 ROOFING**

Roof slopes will be a minimum 6/12. Roof pitch on a Bungalow design will be a minimum of 7/12 and may be required to be increased to ensure an acceptable streetscape. Eave overhangs are to be proportionate to the design of the home. Cantilevers and boxouts on visible elevations (front, corner and perimeter lots) must include their own roofline and overhang. All fascia boards are to be a minimum of 8"

Roof material is to be either:

IKO 25 Year Shingles in the following colors: Weatherwood, Driftwood, Dual Black or Charcoal Grey.

BP 25 Year Shingles in the following colors: Weatherwood, Charcoal Grey, Sandstone, or Slate Black.

All furnace and fireplace chimneys must be contained in a corbeled chase.

#### **10.0 EXTERIOR FINISHES**

The use of window and door surrounds and/or a combination of battens, trim boards, louvers and brick or stone will be a feature on all homes. It is the intent of this clause to ensure all openings visible from the front street will be detailed with appropriate trim.

Brick or stone (masonry) is required on the front of each home. A minimum of 90 sq ft of masonry is required. All entrance treatments and verandahs are to be accented with stone or brick. (masonry)

Permitted cladding materials include vinyl siding and wood siding in horizontal application, brick/stone in stacked application, stucco, and Stonetile.

All trim and masonry details must be returned 24" around corners.

Parging not to exceed 2'0" on front and corner elevations.

An emphasis on entrance treatments is a requirement. Such treatment may include the use of verandahs, courtyards, and covered entries. Where the design does not lend itself to this concept, the use of alternate detailing and feature windows will be considered.

#### **11.0 FENCING**

Wood fencing is acceptable on all lots and as outlined in the foregoing shall be consistent in design and color with the fencing style established for the community, an illustration of which is attached.

#### **12.1 LANDSCAPING**

It is the responsibility of the builder to landscape the front yard. In the case of corner lots the front yard shall include the flanking sideyard to the sidewalk, curb or boulevard and to the rear corner of the house.

The minimum landscape standard shall consist of sod, one tree and a prepared shrub bed containing at least four shrubs. Deciduous trees shall be 2" minimum caliper, coniferous trees a minimum 6' tall, and shrubs shall be a minimum of 2" in height. All landscaping must be completed, in accordance with the requirements, within six months of completion of the house (subject to seasonal limitations).

#### **12.0 ANCILLARY BUILDINGS / GARDEN SHEDS**

The side wall elevations of all ancillary buildings and garden sheds shall not extend higher than adjacent fencing. Where such structures are visible from public adjacencies (i.e. all perimeter lots, corner lots and lots backing onto the lake), exterior wall finishes, style and color shall compliment those used on the house. Roof style and materials are to match the materials used on the roof of the house.

#### **13.0 INTERPRETATION**

The enforcement, administration and interpretation of these guidelines shall be at the discretion of MLC Group or its designated consultant. The unfettered application of these guidelines shall be without notice or precedent.

#### **14.0 SITING**

##### **14.1 Consultant**

Check with the Architectural Consultant and Surveyor for all applicable drawings, and any special conditions.

##### **14.2 City Regulations**

Ensure that city regulations are met and note relevant plans regarding utilities and rights of way.

##### **14.3 Grading**

Check Building Grade Plans and conform to them. Do not grade to existing vacant lots or unfinished

lanes, but to elevations provided.

#### 14.4 Plot Plans

A designated surveyor shall prepare all plot plans and perform all stakeouts in the subdivision to facilitate establishing building elevations that are consistent and appropriate.

### 15.0 SUBDIVISION APPEARANCE

#### 15.1 Signage

In order to maintain cohesiveness for signage within the subdivision, all signage will be supplied by the Developer, i.e. all model signs, directional signs and general information signs. The only signage to be supplied by the Builders Group will be on lots owned or sold by that Builder. Excessive abuse of signage, including sandwich boards may necessitate removal of ALL Builder and Realtor signs.

#### 15.2 Excavation Material

Builders must ensure that all excavation is kept within the confines of their lot. Any spillage on a road, land, sidewalk or neighboring lot must be removed immediately or the Developer will arrange for its removal and invoice for expenses.

#### 15.3 Clean up

Builders should encourage timely removal by all subtrades of litter on building sites. Failure to comply will result in a clean-up bill being charged to the lot. Supply of bins by the Builder is recommended. Any general clean-up of the subdivision implemented by the Developer can and will be charged pro-rata to all builders.

#### 15.4 Construction Activity

Each Builder is responsible for inspecting the condition of curbs, sidewalks, street lights, services, etc. on his lot and must submit written notice of any damages to the Developer prior to commencing construction, otherwise costs for repairing any damages becomes the sole responsibility of the Purchaser/Builder.

### 16.0 APPROVAL PROCESS

Prior to application the Builder has inspected the lot and all services. All discrepancies or damage are to be reported in writing to the Developer.

Before applying to the City for a development permit, the applicant shall submit plans for approval of WINDWARD LANDTEC INC. Application shall include the following:

- a) One complete set of house plans;  $\frac{1}{4}$ " or  $\frac{3}{16}$ " = 1'
- b) Two Copies of the Plot plan, prepared by Stantec Geomatics, 1:300, showing lot house grades and drainage pattern, floor and garage elevations; and
- c) Completed application form.
- d) Material and color samples, as required.

WINWARD LANTEC INC. will review the plan and recommend approval, modification, or rejection of the application based on the adherence of the plans to these guidelines. Should disputes arise, the Developer shall make the final decision on the acceptability of plans. Once approved, WINDWARD LANTEC INC. will send

a copy of the application indicating any changes to the applicant. After approval, the plans may not be altered without prior approval of WINDWARD LANTEC INC. WINDWARD LANTEC INC. will keep an up-to-date record of plans showing house types, color, roof lines and grades, to advise the applicants of how their proposed house will best fit into the existing situation.

#### 17.0 DAMAGE DEPOSITS

The Builder shall supply a damage deposit or Letter of Credit in the amount of \$5,000.00 (regardless of the number of lots) is due prior to house plan and grade approval to cover:

1. Contravention of architectural objectives.
2. Possible damage to:
  - (a) Curb stop - water valve
  - (b) Sidewalks, curbs and gutters
  - (c) Driveway aprons and asphalt
  - (d) Boulevard landscaping and trees
  - (e) Rear gutters and walkways
  - (f) Light standards
  - (g) Fire hydrants
  - (h) Cathodic Protection points
  - (i) Grading and drainage swales
  - (j) Fencing

#### 17.1 Deposit Return Procedure

1. Exterior completed in accordance with these guidelines and as approved by the architectural consultant.
2. Landscaping satisfactorily completed as per requirements.
3. Rough grading certificate & city approval of same, from the City of Edmonton Drainage Branch.
4. Water valve exposed and marked.
5. Sidewalks, street, lane, gutters and curbs cleaned.
6. Application made in writing to WINDWARD LANDTEC INC. (form attached).

Upon completion of construction, site works and landscaping, a final inspection is done to ensure compliance with the architectural guidelines and to check for any damages to municipal improvements. The following items must be completed prior to a request for final inspection:

- \* Home constructed in compliance with the Guidelines and the approved plan
- \* Construction complete including seasonal work on exterior, site cleared of all debris, sidewalks and curbs cleaned, cc marked and exposed
- \* Landscaping completed in accordance with guideline requirements
- \* Grading certificate for rough grade is provided with City approval

To initiate the final inspection, a request form accompanied by the approved grading certificate must be forwarded by the builder to Windward Landtec Inc.

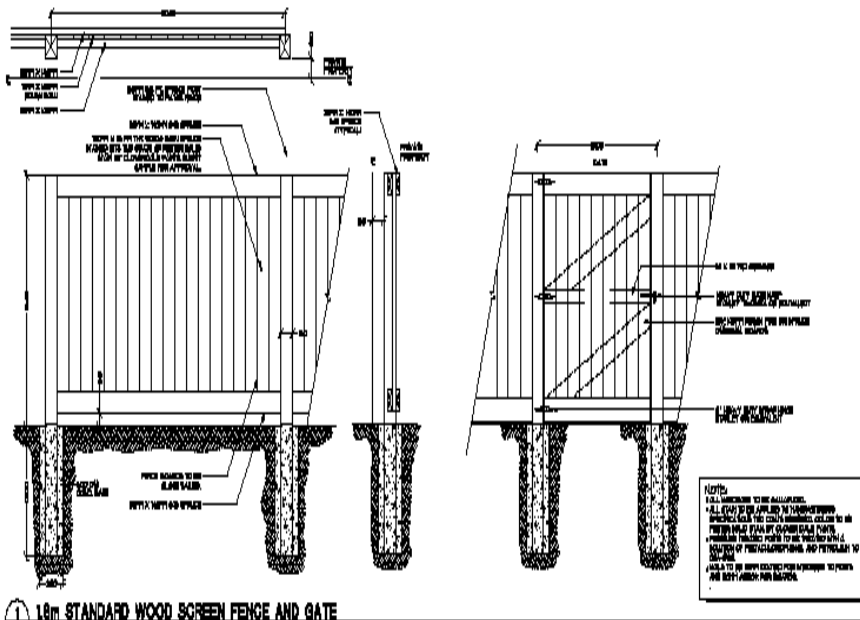

1.8m STANDARD WOOD SCREEN FENCE AND GATE  
SCALE: N.T.S.

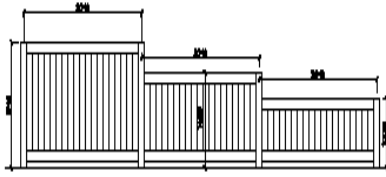

WOOD SCREEN FENCE STEP DOWN  
SCALE: N.T.S.

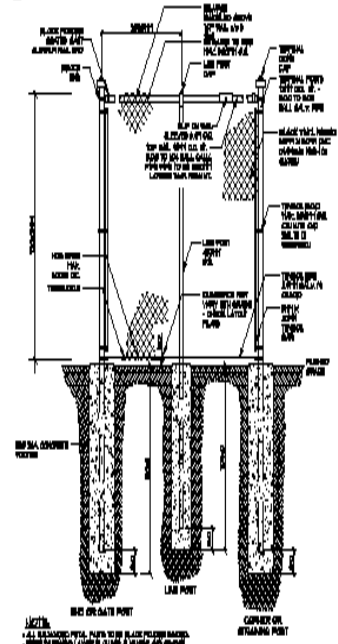

1200mm BLACK VINYL COATED CHAIN LINK FENCE DETAIL  
SCALE: N.T.S.

**CHAIN LINK FENCING NOTES:**

1. ALL DIMENSIONS SHALL BE IN MILLIMETERS UNLESS OTHERWISE NOTED.
2. THE GATE SHALL BE 1.8m HIGH AND 1.8m WIDE.
3. ALL DIMENSIONS SHALL BE IN MILLIMETERS UNLESS OTHERWISE NOTED.
4. ALL DIMENSIONS SHALL BE IN MILLIMETERS UNLESS OTHERWISE NOTED.
5. ALL DIMENSIONS SHALL BE IN MILLIMETERS UNLESS OTHERWISE NOTED.
6. ALL DIMENSIONS SHALL BE IN MILLIMETERS UNLESS OTHERWISE NOTED.
7. ALL DIMENSIONS SHALL BE IN MILLIMETERS UNLESS OTHERWISE NOTED.
8. ALL DIMENSIONS SHALL BE IN MILLIMETERS UNLESS OTHERWISE NOTED.
9. ALL DIMENSIONS SHALL BE IN MILLIMETERS UNLESS OTHERWISE NOTED.
10. ALL DIMENSIONS SHALL BE IN MILLIMETERS UNLESS OTHERWISE NOTED.

**WOOD SCREEN FENCING NOTES:**

1. ALL DIMENSIONS SHALL BE IN MILLIMETERS UNLESS OTHERWISE NOTED.
2. THE GATE SHALL BE 1.8m HIGH AND 1.8m WIDE.
3. ALL DIMENSIONS SHALL BE IN MILLIMETERS UNLESS OTHERWISE NOTED.
4. ALL DIMENSIONS SHALL BE IN MILLIMETERS UNLESS OTHERWISE NOTED.
5. ALL DIMENSIONS SHALL BE IN MILLIMETERS UNLESS OTHERWISE NOTED.
6. ALL DIMENSIONS SHALL BE IN MILLIMETERS UNLESS OTHERWISE NOTED.
7. ALL DIMENSIONS SHALL BE IN MILLIMETERS UNLESS OTHERWISE NOTED.
8. ALL DIMENSIONS SHALL BE IN MILLIMETERS UNLESS OTHERWISE NOTED.
9. ALL DIMENSIONS SHALL BE IN MILLIMETERS UNLESS OTHERWISE NOTED.
10. ALL DIMENSIONS SHALL BE IN MILLIMETERS UNLESS OTHERWISE NOTED.

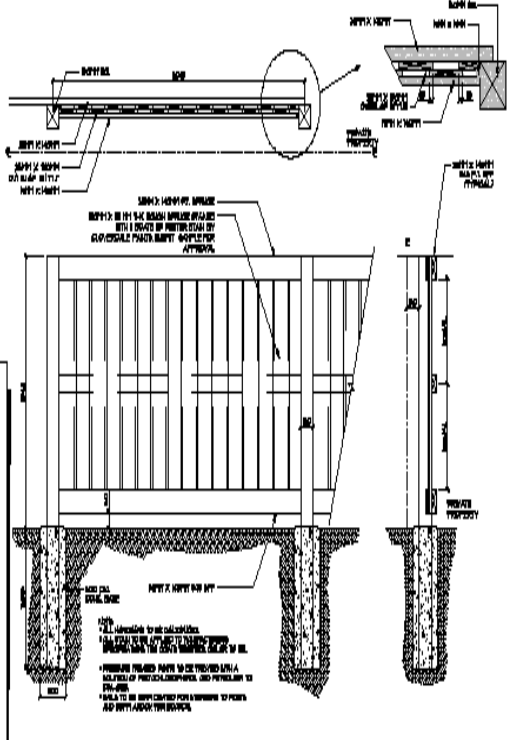

OVERLAP BOARD WOOD SCREEN FENCE  
SCALE: N.T.S.

**SouthPointe Ltd**  
 1111 Street  
 Edmonton AB Canada  
 T6E 2L3  
 Tel: 781.171.2665  
 Fax: 781.171.2666  
 www.southpointe.ca

**SouthPointe**

The Contractor shall verify and be responsible for all dimensions. It is the Contractor's responsibility to ensure that all dimensions are correct and to report to SouthPointe Ltd. immediately if any discrepancies are identified.

The Contractor is to ensure that all work is done in accordance with the SouthPointe Ltd. Standards and to ensure that all work is done in accordance with the SouthPointe Ltd. Standards.

**Legend**

**Notes**

1. All dimensions shall be in millimeters unless otherwise noted.	2. The gate shall be 1.8m high and 1.8m wide.	3. All dimensions shall be in millimeters unless otherwise noted.	4. All dimensions shall be in millimeters unless otherwise noted.	5. All dimensions shall be in millimeters unless otherwise noted.	6. All dimensions shall be in millimeters unless otherwise noted.	7. All dimensions shall be in millimeters unless otherwise noted.	8. All dimensions shall be in millimeters unless otherwise noted.	9. All dimensions shall be in millimeters unless otherwise noted.	10. All dimensions shall be in millimeters unless otherwise noted.
---	---	---	---	---	---	---	---	---	--

**SouthPointe Estates Inc**

**SOUTHPOINTE STAGE 1**

Part 08 - Fencing, Gates

**Details**

Page: 7 of 10





Subdivision \_\_\_\_\_  
 Lot \_\_\_\_\_ Block \_\_\_\_\_ Plan \_\_\_\_\_  
 Homeowner \_\_\_\_\_  
 Municipal Address \_\_\_\_\_



**APPLICANT INFORMATION**

Name \_\_\_\_\_  
 Address \_\_\_\_\_  
 City \_\_\_\_\_ PC \_\_\_\_\_ Tel \_\_\_\_\_ Fax \_\_\_\_\_  
 Job No \_\_\_\_\_



**HOUSING DESIGN**

Type Bungalow  Bi-Level  Split Level  Two Storey  Other

Area Main Floor \_\_\_\_\_ Second Floor \_\_\_\_\_ Total Floor \_\_\_\_\_ Sq.Ft. \_\_\_\_\_

Form Roof Style \_\_\_\_\_ Roof Pitch/Slope \_\_\_\_\_ Fascia Size \_\_\_\_\_

Exterior Detail	Manufacturer	Material	Colour
Roof	_____	_____	_____
Wall	_____	_____	_____
Brick / Stone	_____	_____	_____
Trim	_____	_____	_____
Soffit, Fascia	_____	_____	_____
Window	_____	_____	_____
Front Door	_____	_____	_____
Garage Door	_____	_____	_____
Chimney	_____	_____	_____
Driveway	_____	_____	_____
Driveway Border	_____	_____	_____
Verandah	_____	_____	_____

NOTE:  
 Colour - Please specify Manufacturer's name, reference number and colour: Example, Olympic 704 Brown  
 Siting and grades as per surveyors plot plan.  
 Conformance to setback and lot grading requirements are the responsibility of purchaser and /or builder.

USE OF HOUSE PLAN APPROVAL SERVICES  
 The Applicant acknowledges that the house plan approval is provided as a service and that the developer and its designated consultants assume no responsibility for the accuracy of the information provided, or for any losses or damages resulting from use thereof. The applicant further acknowledges that they will hold the developer and its designated consultants harmless from any action resulting from the use of this information.

Date \_\_\_\_\_ Signature \_\_\_\_\_  
 12128 - 121A Street, Edmonton Alberta T5L 0A4 Tel. 780.454.6799 Fax: 780.454.6896 email: info@windwardlandtec.com

APPLICATION FOR HOUSE PLAN APPROVAL